



Guidelines for Thermal Insulation

Implementation in Buildings

Electricity Conservation Section

1. Introduction	3
2. Laws and Regulations	5
3. Technical and Engineering Definitions	7
4. Measurements for Thermal Insulation Implementation	9
5. Thermal Insulation Requirements:	12
6. Properties and specifications of thermal insulation materials	14
7. Implementation Procedure	15
8. Procedure of Thermal Insulation Audit by EWA.....	17
9. Benayat Building Permit Portal.....	19
10. Appendix	21

1. Introduction

Energy is consumed in buildings for air-conditioning, lighting, cooking, cleaning, recreation ... etc. Reports and studies, which were conducted in Bahrain, revealed that more than 65% of energy is consumed by air conditioning. The rate of energy consumption by air-conditioning is influenced by three main factors:-

1. Thermal performance of the building, which is affected by a number of factors, such as building form, building orientation, glazed surface areas, and thermophysical properties of building materials of the envelope of the building.
2. User's behavior in terms of controlling air-conditioning, lighting and other equipment.
3. General policy of the nation with respect to energy cost, building rules and regulations.

No doubt that the building form, building layout, building design and thermophysical properties of used building materials have considerable influence on the amount of energy needed for the provision of indoor thermal comfort requirements. Therefore it is the duty of architects and designers to conduct the required analytical studies, which lead to benefit from the climatic factors with the objective of reducing the need for air-conditioning and maximum utilization of natural lighting.

Studies revealed that the thermal characteristics of the building envelope are one of the main criteria, which determine the overall thermal performance. For this reason, a code for thermal insulation is introduced. The code deals with the thermal characteristics of roofs, external walls, and glazed surfaces with the objective of reducing heat flow through the building envelope. This is done through limiting of the U-value for roofs and external walls together with defining the type of glass for windows and openings. The use of insulation materials is regarded as the most effective with respect to reducing the rate of heat transfer from outside to inside during the hot summer, and from inside to outside during the cold winter.

Heat transfer to and from the building takes place through the following: -

1. Walls and roofs.
2. Windows and glazed surfaces.
3. Openings.

During summer, the amount of heat transfer through roofs and walls ranges between 60-70%. This amount of heat should be removed by air-conditioning. Therefore the use of insulation materials for roofs and walls is very essential for energy conservation. Thermal insulation has many advantages, such as: -

1. Reducing the energy consumption required for cooling and heating.
2. Reducing the capacity of air-conditioning equipment and hence reducing capital cost.
3. Protecting the building components from thermal stress as a result of expansion and contraction.
4. Reducing the electricity bill for consumers.
5. The provision of comfortable indoor thermal environment.
6. Protecting the surrounding environment from harmful gases emitted by electric power plants.

Windows and glazed surfaces are considered as the weakest points with regard to heat transfer by conduction and radiation. Therefore, it is advisable to reduce the area of glazed surfaces, which are exposed to external climate and direct solar radiation and encourage the use of high performance glass and double-glazing.

2. Laws and Regulations

2.1 Thermal Insulation Order # 8/1999:

Was issued in 1999 by H.E. The Minister of Housing & Municipality making it compulsory to provide thermal insulation for all buildings in Kingdom of Bahrain from 5 floors and above, which require air-conditioning. The Order stipulates the following requirements:

- A. Thermal insulation materials should be used for roofs and walls of all buildings which require air-conditioning according to the following:-
- The overall thermal transmittance value (U-value) for the roof should not exceed $0.6 \text{ W/m}^2\text{-}^\circ\text{C}$
 - The overall thermal transmittance value (U-value) for external walls should not exceed $0.75 \text{ W/m}^2\text{-}^\circ\text{C}$.
 - High performance glass should be used for all buildings with more than three floors or if the area of the glazed surfaces ranges between 10-20% of the total external surface area of the building envelope. On the other hand, if the glazed area is more than 20%, double glazing should be used.
- B. This regulation is applicable on all new buildings, which need air-conditioning, and for existing buildings that need to be reconstructed or refurbished. The order has been implemented for buildings above four floors.

2.2 Thermal Insulation Order # 63/2012:

Was issued in 2012 by H.E. The Minister of Housing & Municipality making it compulsory to provide thermal insulation for all residential buildings, facilities, warehouses and stores that need cooling/air-conditioning. Accordingly all buildings below 5 floors which were not covered in the previous thermal insulation order (8/1999) are now required to be provided with thermal insulation. This order has come effective on 1st September 2013, and the following are the requirements of thermal insulation:

- a. Thermal insulation shall be provided for all external walls including exposed columns, beams, stair cases and light wells/shafts. External walls of the building abutting adjoining building(s) if any shall also be insulated.
- b. Thermal insulation shall be provided for the roof including swimming pool decks and stair cases/lift machine rooms.
- c. Floors and walls of air-conditioned spaces exposed to non-air-conditioned spaces like car park/service areas in the building should be insulated.
- d. Spandrel areas of curtain walls should be insulated.

2.3 Thermal Insulation Order # 149/2018:

Was issued on 31st of October 2018 by H.E. Minister of Works, Municipalities Affairs and Urban Planning. It was published in the official Gazette on 1st of November 2018. The order is legally binding effective 1st March 2019. The main clauses of the technical regulation attached with the order are summarized in section 3 below.

3. Technical and Engineering Definitions

The following terms can be defined as follows:

- Overall Heat Transfer Coefficient (U_T): It is the term associated with the rate of heat transfer through the structural elements of the building. It is the rate of time a unit of heat can pass through a unit area of the material layers that make up the structural section, starting with the layer of air in contact with the hot surface and ending with the layer of air in contact with the cold surface. The lower its value, the better the thermal performance of the structure. The unit of measurement for the overall heat transfer coefficient is watts per square meter per degree Kelvin (W/m^2K).
- Thermal conductivity (k): It is the rate of heat transfer in a unit of thickness of a homogeneous material at a difference of one degree in the temperature between the two surfaces of the material. Thermal conductivity depends on the density, porosity, moisture content, and specific heat of the material, and its unit of measurement is in watts per meter per degree Kelvin (W/mK).
- Thermal resistivity (r): It is a measure of a material's resistance to heat transfer through a unit of thickness of a homogeneous material at a difference of one degree in the temperature between the two surfaces of the material. It is also called specific thermal resistance or density thermal resistance. Its unit of measurement is in meter per degree Kelvin per watt (m^2K/W).
- Thermal conductance (C): It is the rate of heat transfer through a material or group of materials making up the structure through a unit of area at a difference of one degree Celsius, and its unit of measurement is in watts per square meter per degree Celsius ($W/m^2.^\circ C$). It is calculated by dividing thermal conductivity by thickness: ($C = k/d$)
- Thermal resistance (R): It is the extent to which a material resists the flow of heat through a unit area of a homogeneous material at a difference in temperature between the two surfaces of the material. It is the reciprocal of thermal conductance, and its unit of measurement is in square meters per degree Celsius per watt ($m^2.^\circ C /W$). It is calculated by dividing thickness by thermal conductivity: ($R = d/k$)
- Surface thermal resistance (R_s): It is the extent to which a layer of air in contact with the surface of a material resists the flow of heat through it. It is divided into two parts: R_i , which is the resistance of the layer of air in contact with the internal surface. R_o , which is

the resistance of the layer of air in contact with the external surface. The table below under the second item of this attachment shows the average values for it in the atmosphere of the Kingdom of Bahrain.

- Cavity thermal resistance (R_c): It is the extent to which the air gap between two materials resists the flow of heat through it. It depends on several factors, the most important of which are the thickness of the air gap and the type of surfaces facing each other. Its unit of measurement is in square meters per degree Celsius per watt (m^2K/W).
- Total thermal resistance (R_T): It is the sum of the thermal resistances of the different layers of the structure (from the layer of air in contact with the external surface to the layer of air in contact with the internal surface). Its unit of measurement is in square meters per degree Celsius per watt (m^2K/W).
- Reflectance: It is a measure of a surface's ability to reflect sunlight. It ranges from 0 to 1. The higher the reflectance of the surfaces of the roofs, the greater their ability to reflect sunlight.
- Emittance: It is the ability of materials to dissipate the heat absorbed in it. It ranges from 0 to 1.

4. Measurements for Thermal Insulation Implementation

The measurements of the following parameters are carried out in accordance with the equations set forth below, taking into account the meanings of the symbols contained therein and explained as follows:

(a) The symbols used in the following equations refer to the words and expressions shown next to each of them:

- Watt (W)
- Meter (m)
- Square meter (m²)
- Celsius degree (C)
- British thermal unit (Btu)
- Unit of measurement for temperature (K)
- Inch (in)
- Hour (hr)
- Foot (ft.)
- Square foot (ft²)
- Fahrenheit degree (F)

(b) The following equations are used to measure the coefficients and resistances mentioned in the above technical Definitions:

1- Thermal conductivity (k or λ):

$$k = \frac{W}{m.K} \text{ or } \frac{Btu.In}{hr.ft^2.F}$$

2- Specific thermal resistance (thermal density) (ρ and r):

$$r = 1 / k = \frac{m.K}{W} \text{ or } \frac{hr.ft^2.F}{Btu.in}$$

3- Thermal resistance (R):

$$R = L \times r = \frac{K.m^2}{W} \text{ or } \frac{ft^2.hr.F}{Btu}$$

Where L is the thickness of the material.

Noting that the greater the thermal resistance of the material, the better the material is in terms of thermal insulation.

4- Total thermal resistance (R_T):

$$R_o + R_i + \dots + R_2 + R_T = R_1$$

Where R_i is the resistance of the layer of air adjacent to the internal surface, and R_o is the resistance of the layer of air adjacent to the external surface. The table below shows the average values for it in Bahrain atmosphere:

Thermal resistance for adjacent air layer		
Section	Interior thermal resistance	Outside thermal resistance
	(R_i)	(R_o)
Wall	0.121	0.059
Roof	0.166	0.059

5- Overall Thermal Transmittance (U_T):

$$U_T = 1 / RT$$

It is measured in W/m^2K or $Btu/ft^2hr \cdot ^\circ F$.

6- Overall U Value (U_{value}):

When using different insulation systems in the components of the external walls, the average heat transfer coefficient can be calculated by taking the average of the heat transfer coefficient of all these components according to their areas as follows:

$$U_{value} = (A_1 * U_1 + A_2 * U_2 + \dots + A_N * U_N) / (A_1 + A_2 + \dots + A_N)$$

Where A_i is the area in square meters, and U_i is the heat transfer coefficient of each part of the walls.

7- Calculation of the thermal resistance for air gaps (R_c):

The following values can be used for the thermal resistance (R_c):

- For a gap with a thickness of more than 5 mm to 20 mm:

$$R_c = 0.11 \text{ m}^2\text{K/W}$$

- For a gap with a thickness of more than 20 mm:

$$R_c = 0.18 \text{ m}^2\text{K/W}$$

5. Thermal Insulation Requirements:

1. Maximum U-values for the roofs and walls shall be as follows:

Table (1)	
Thermal Insulation	Maximum of Thermal Transmittance Value U Value (W/m².C)
Roofs	0.3
Walls	0.57

2. Glazed surfaces should comply with the following:

Table (2)			
Glass Area	Max. U-Value (W/m².C)	Max. Shading Coefficient	Min. Light Transmission
Glass percentage less than or equal 40%	2.1	0.4	0.25
Glass percentage more than 40%	1.9	0.3	0.20
Skylights & Roof Openings	1.9	0.25	0.10
Shopfronts and Showrooms	1.9	0.76	-

3. In addition, all facades, surfaces and balconies that are exposed to external weather must also be insulated. All precautions should be taken to eliminate thermal bridges in walls, roofs, and windows/doors.

4. The roof surfaces should be cooled or coated to reflect sunlight, with the reflectance coefficient (Reflectance) not less than 0.65 and the emissivity coefficient (Emittance) not less than 0.75. Roofs containing photovoltaic panels or special designs for surface uses, such as the using of aggregates to cover certain services for maintenance purposes, using tiles, or designing gardens or restaurant terraces are exempted from this requirement.

6. Properties and specifications of thermal insulation materials

1. All thermal insulation materials that are intended to be used in the external walls and roofs of buildings must be approved by the Electricity and Water Authority of the Kingdom of Bahrain in accordance with the requirements and regulations of the Authority.
2. Internal Thermal insulation materials used in roofs and walls must be fire resistant and non-toxic when exposed to fire. The specifications and requirements of fire resistance must also be approved by the relevant authority of the General Directorate of Civil Defense.
3. In calculating the overall heat transfer coefficient of insulation materials used in roofs and external walls, the technical data issued by the Electricity and Water Authority are used in accordance with the approved test reports. The Electricity and Water Authority has the right to visit the sites to take the necessary samples for testing and surveys and to verify the validity and compliance of these data.
4. When installing thermal insulation for roofs and walls of a building, the following should be taken into account:
 - a. The insulation materials should be stored in dry, covered areas to protect them from moisture.
 - b. The insulation materials should be inspected before installation to ensure that they are free of cracks ,holes ,tears ,or grease.
 - c. Wall insulation materials should be covered on both sides with a moisture barrier to protect them from moisture from both inside and outside the walls.
 - d. Roof insulation materials should be covered on both sides with a barrier or sheathing from above and another barrier resistant to water absorption from below.

7. Implementation Procedure:

For buildings with a Built-up area of 10,000 sqm and above:

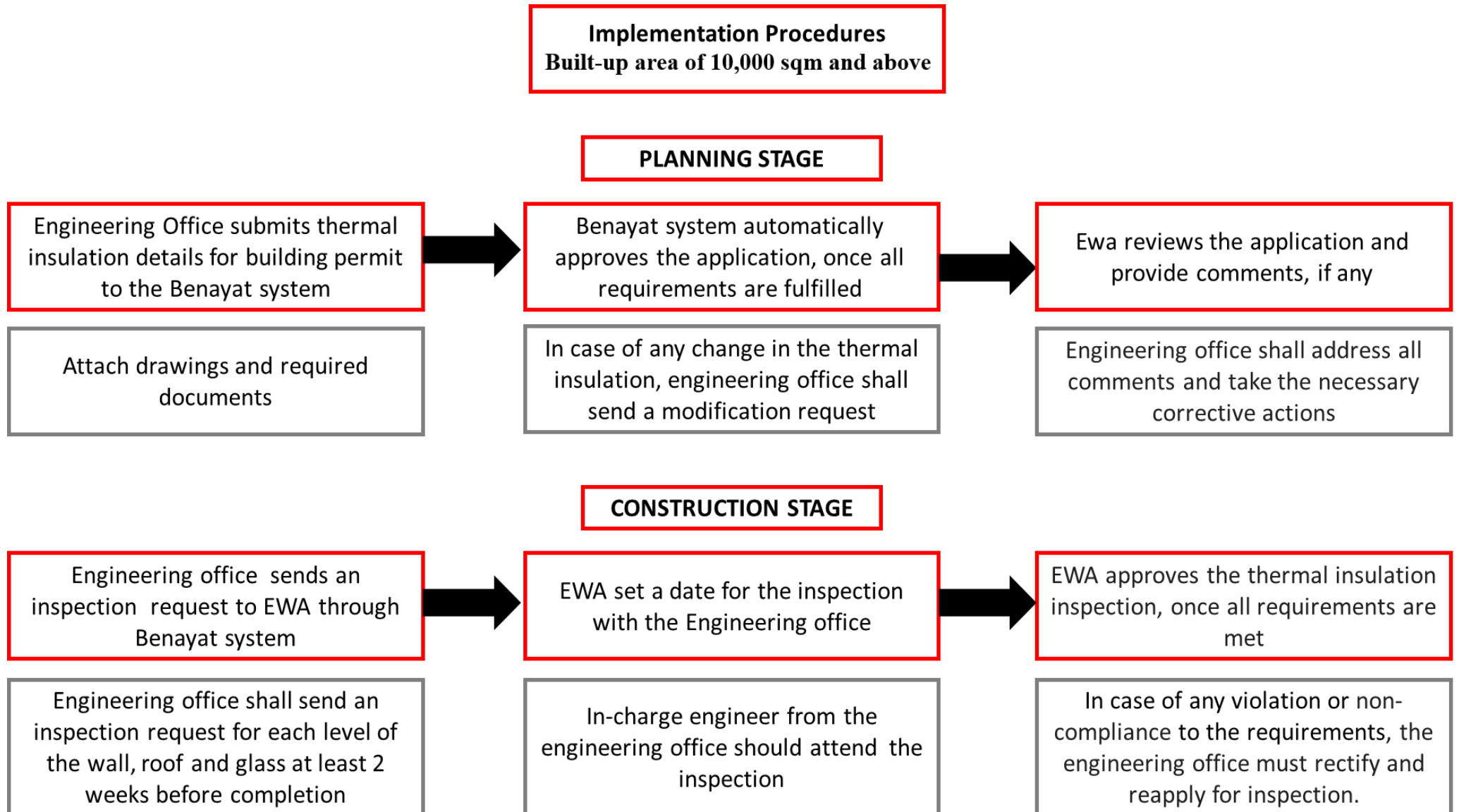

For buildings with a Built-up area less than 10,000sqm:

**Implementation Procedures
Built-up area less than 10,000sqm**

PLANNING STAGE

Engineering Office submits thermal insulation details for building permit to the Benayat system

Benayat system automatically approves the application, once all requirements are fulfilled

Attach drawings and required documents

Any modification on the thermal insulation should be updated in the related documents

CONSTRUCTION STAGE

Engineering office sends an inspection request through Benayat system

Engineering office contacts the contractor to set a date for the inspection

Engineering office approves the thermal insulation inspection, once all requirements are met

Engineering office to coordinate the inspection with the owner and the contractor for each level of the wall, roof and glass

In-charge engineer from the engineering office must attend the inspection

In case of any violation or non-compliance to the requirements, the contractor must rectify and request for new inspection

8. Procedure of Thermal Insulation Audit by EWA

Electricity and Water Authority (EWA) conducts regular audits of engineering offices who want to obtain a license to practice thermal insulation application in buildings. This is to ensure that the offices have qualified staff to carry out thermal insulation, and to verify that the offices comply with the requirements and provisions of the thermal insulation decision in buildings, at the planning and construction stages, especially in buildings with a buildup area less than 10,000 square meters, which are directly supervised by the engineering offices.

Audit procedures for engineering offices by EWA:

1. Audit request:

The engineering office has to submit a request to EWA to conduct a thermal insulation audit at least three months before the expiration date of the current license certificate.

2. Audit date:

EWA will send a letter to the engineering office stating the date of the audit and a list of requirements.

3. Audit requirements:

The engineering office shall submit the list of audit requirements and appoint a certified engineer by EWA to coordinate and follow up.

4. Audit projects:

EWA will select one or more projects, which completed or under construction, with a building area less than 10,000 square meters.

5. Project documents:

The engineering office shall submit the documents of the selected project for audit, such as building permit, thermal insulation forms, architectural/structural/sectional design drawings, glass details, roof coating details, property owner's declaration, and construction inspection reports.

6. Review of documents and on-site visit:

EWA engineer will review the submitted documents and verify the implementation of thermal insulation on site.

7. Audit report:

EWA will issue a report of the audit results, which will include EWA's observations on the performance of the engineering office and its compliance with the application of thermal insulation in buildings.

8. Review of the report:

The engineering office will review the report and respond to the observations, if any, sign the report, and return it to EWA.

9. Corrective action plan:

In the event of a violation mentioned in the audit report, the engineering office shall submit a corrective action plan and a written commitment to not repeat the violation and to comply with all thermal insulation requirements.

10. Thermal insulation certificate:

EWA will issue a thermal insulation certificate for a specified period based on the performance of the engineering office, its response to the audit report, the results of the interview with the office's engineers, and the correction of the violation (if any).

9. Benayat Building Permit Portal

Electricity and Water Authority (EWA), in cooperation with the eGovernment Authority, has started the Electronic Licensing for thermal insulation implementation in Building Permit Applications (Benayat System). Under this system, the application and licensing process for building permits is carried out automatically. The system has been designed to include a database of all building materials approved by Ewa to be used in thermal insulation implementation. The mechanism for electronic licensing of thermal insulation requests can be summarized as follows:

1. The user (engineering office) registers to enter the Benayat website by entering his/her username and password.
2. The user enters the project details and then enters the thermal insulation section.
3. The user selects the parts of the building for which he/she wants to design the thermal insulation, such as roofs, walls, and glass.
4. The user selects the thermal insulation materials from the list listed on the website, according to the thermal insulation requirements of the building.
5. The engineering office determines the other technical details such as areas, thickness of the insulation material used, area of the building facade and windows, and other requirements.
6. The electronic system (Benayat) calculates the values of the thermal conductivity (U value), and the other technical values, and verifies that all thermal insulation requirements are met.
7. The electronic system (Benayat) issues the building permit automatically, after verifying that all requirements are met.

The following diagram illustrates the details of this mechanism in brief:

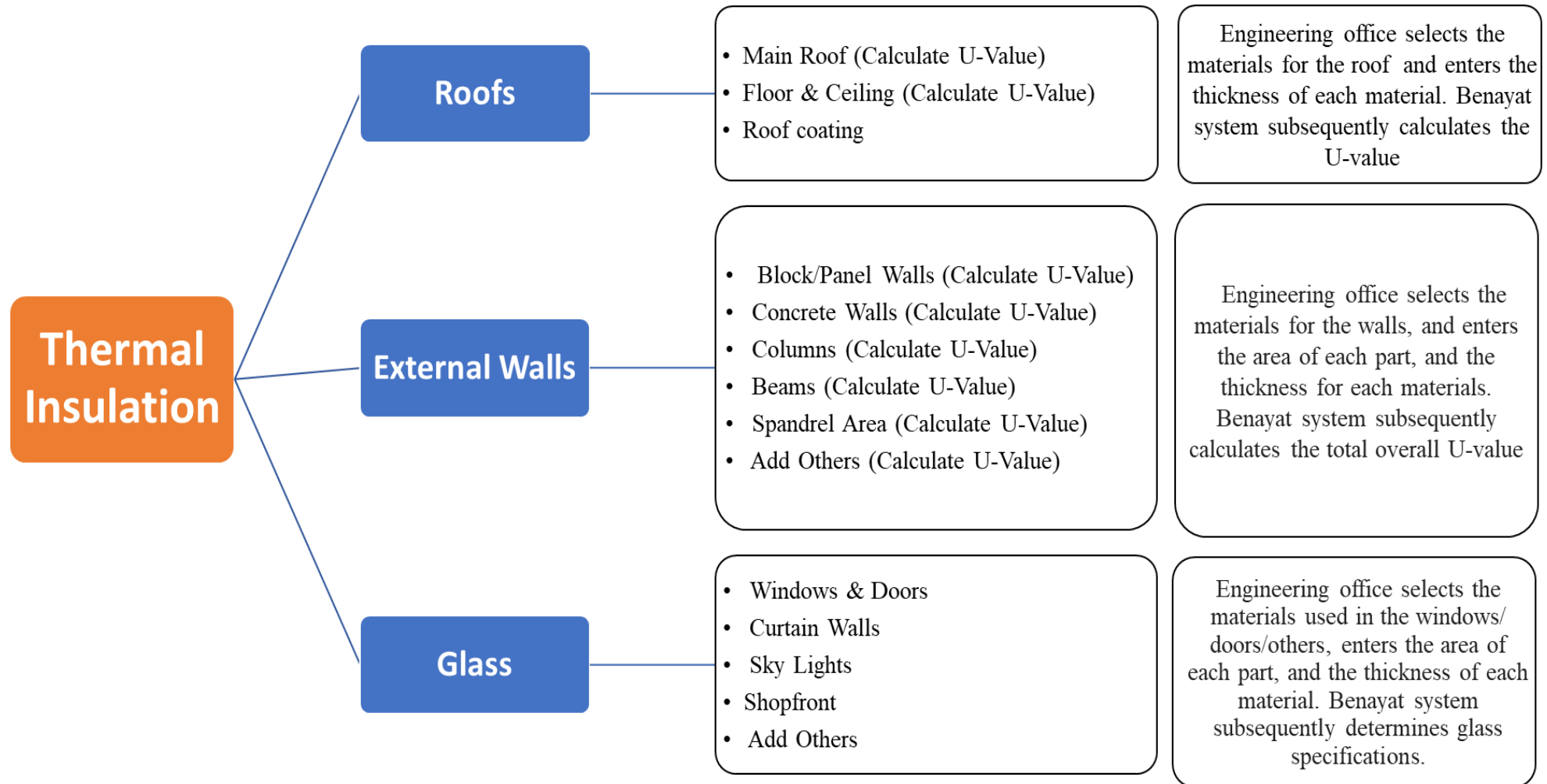

Appendix

Appendix (1): Cross Sections Samples for Wall Thermal Insulation Systems

Appendix (2): Thermal Insulation Implementation Forms

Appendix (3): Approval Procedures for Thermal Insulation Products

Appendix (1)

Cross Sections Samples for Wall Thermal Insulation Systems

Thermal Insulation Systems for Walls:

AAC Blocks:

- Mfg / Suppliers: Insulated Building Systems Factory - Kingdom of Bahrain

Sr. No.	Element	Density Kg/m ³	Thickness (mm)	Thermal Conductivity W/m.K	Thermal Resistance m ² .K/W
1	Ext. Surface Resistance				0.059
2	External Plaster	1800	15	0.75	0.020
3	AAC Block	528	200	0.13	1.550
4	Internal Plaster	1800	15	0.75	0.020
5	Int. Surface Resistance				0.121
Total Thermal Resistance (R) m ² .K/W					1.770
Total Thermal Transmittance (U-value) W/m².K					0.565

- Mfg / Suppliers: Saudi Acico Co. LTD. (KSA) / Bahrain Blocks

Sr. No.	Element	Density Kg/m ³	Thickness (mm)	Thermal Conductivity W/m.K	Thermal Resistance m ² .K/W
1	Ext. Surface Resistance				0.059
2	External Plaster	1800	15	0.75	0.020
3	AAC Block	465	200	0.12	1.667
4	Internal Plaster	1800	15	0.75	0.020
5	Int. Surface Resistance				0.121
Total Thermal Resistance (R) m ² .K/W					1.887
Total Thermal Transmittance (U-value) W/m².K					0.530

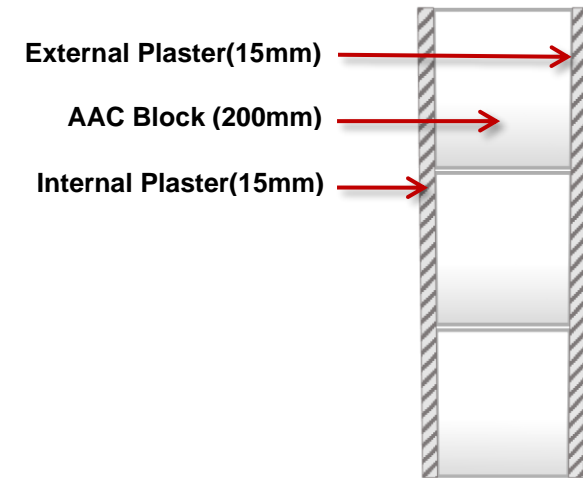

AAC Block
Autoclaved aerated concrete block

IMSI Blocks:

- Mfg / Suppliers: Redx Industries Kingdom of Bahrain

Sr. No.	Element	Density Kg/m ³	Thickness (mm)	Thermal Conductivity W/m.K	Thermal Resistance m ² .K/W
1	Ext. Surface Resistance				0.059
2	External Perlite Plaster (Gulf perlite)	408	26	0.08	0.325
3	IMSI Block	2420	200	0.2024	0.988
4	Internal Perlite Plaster (Gulf perlite)	408	26	0.08	0.325
5	Int. Surface Resistance				0.121
Total Thermal Resistance (R) m ² .K/W					1.759
Total Thermal Transmittance (U-value) W/m².K					0.568

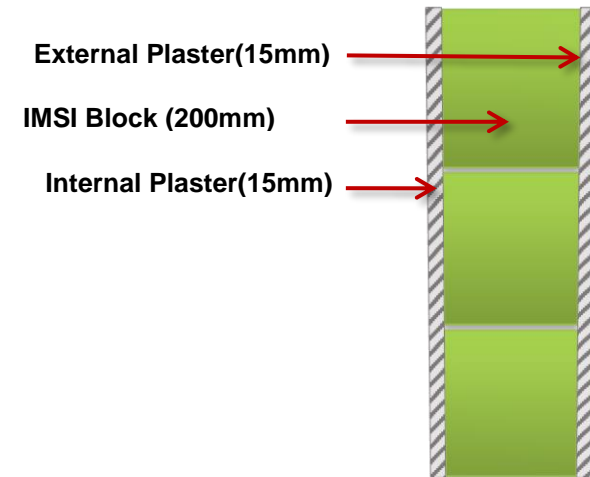

IMSI Block
Concrete blocks with expanded polystyrene

Sandwich Block:

- Mfg / Suppliers: Ahmed Rashid Al-Jalahma & Sons Co - Kingdom of Bahrain

Sr. No.	Element	Density Kg/m ³	Thickness (mm)	Thermal Conductivity W/m.K	Thermal Resistance m ² .K/W
1	Ext. Surface Resistance				0.059
2	External Plaster	1800	15	0.75	0.020
3	Sandwich Block	2360	200	1.246	1.605
4	Internal Plaster	1800	15	0.75	0.020
5	Int. Surface Resistance				0.121
Total Thermal Resistance (R) m ² .K/W					1.825
Total Thermal Transmittance (U-value) W/m².K					0.548

- Mfg / Suppliers: Al-Manaratain Co. - Kingdom of Bahrain

Sr. No.	Element	Density Kg/m ³	Thickness (mm)	Thermal Conductivity W/m.K	Thermal Resistance m ² .K/W
1	Ext. Surface Resistance				0.059
2	External Plaster	1800	15	0.75	0.020
3	Sandwich Block	465	200	0.1251	1.599
4	Internal Plaster	1800	15	0.75	0.020
5	Int. Surface Resistance				0.121
Total Thermal Resistance (R) m ² .K/W					1.819
Total Thermal Transmittance (U-value) W/m².K					0.550

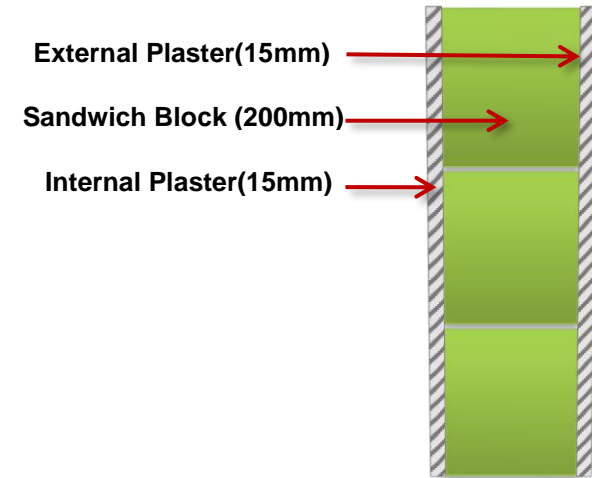

**Sandwich Block
Concrete blocks with expanded
polystyrene**

Cavity Wall(Expanded Polystyrene):

-Mfg / Suppliers: Expanded polystyrene: Noor Factories (BH)

Sr. No.	Element	Density Kg/m ³	Thickness (mm)	Thermal Conductivity W/m.K	Thermal Resistance m ² .K/W
1	Ext. Surface Resistance				0.059
2	External Plaster	1800	15	0.75	0.020
3	Concrete Block	2100	200	0.885	0.226
4	EPS	22.5	60	0.0397	1.511
5	Concrete Block	2100	100	0.602	0.166
6	Internal Plaster	1800	15	0.75	0.02
7	Int. Surface Resistance				0.121
Total Thermal Resistance (R) m ² .K/W					2.123
Total Thermal Transmittance (U-value) W/m².K					0.471

-Mfg / Suppliers: Extruded polystyrene: Fabco Plastic Factory(KSA)

Sr. No.	Element	Density Kg/m ³	Thickness (mm)	Thermal Conductivity W/m.K	Thermal Resistance m ² .K/W
1	Ext. Surface Resistance				0.059
2	External Plaster	1800	15	0.75	0.020
3	Concrete Block	2100	200	0.885	0.226
4	Insulated Board	35	60	0.0348	1.724
5	Concrete Block	2100	100	0.602	0.166
6	Internal Plaster	1800	15	0.75	0.02
7	Int. Surface Resistance				0.121
Total Thermal Resistance (R) m ² .K/W					2.336
Total Thermal Transmittance (U-value) W/m².K					0.428

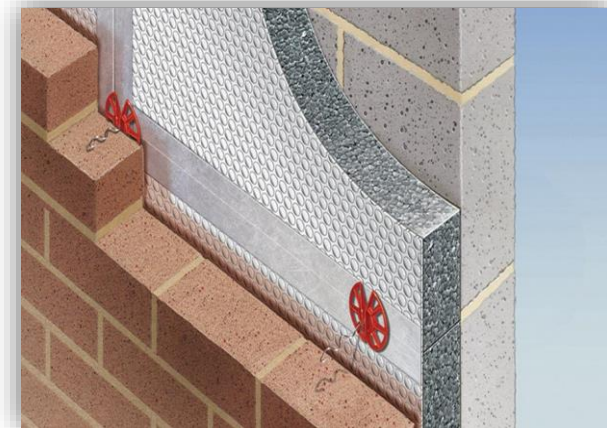
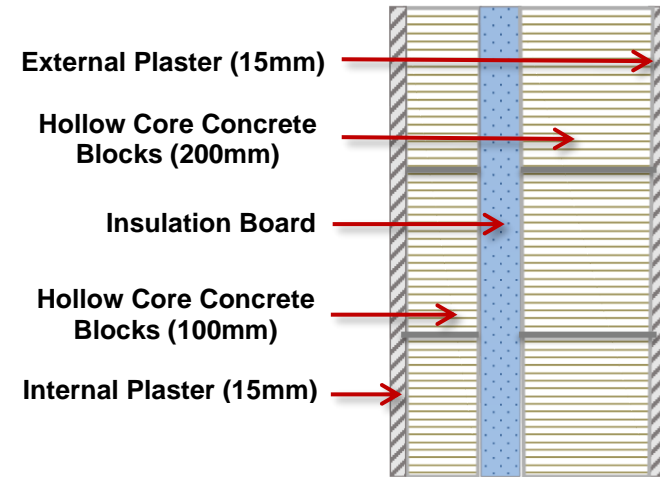

External Thermal Insulation System with Expanded Polystyrene:

- Mfg / Suppliers: Henkel Industries (UAE) / Bader Trading & Contracting

Sr. No.	Element	Density Kg/m ³	Thickness (mm)	Thermal Conductivity W/m.K	Thermal Resistance m ² .K/W
1	Ext. Surface Resistance				0.059
2	Internal Plaster	1800	15	0.75	0.020
3	Concrete Block	2100	200	0.885	0.226
4	EPS	20	50	0.0363	1.377
5	Finishing	-	-	-	-
6	Int. Surface Resistance				0.121
Total Thermal Resistance (R) m ² .K/W					1.803
Total Thermal Transmittance (U-value) W/m².K					0.555

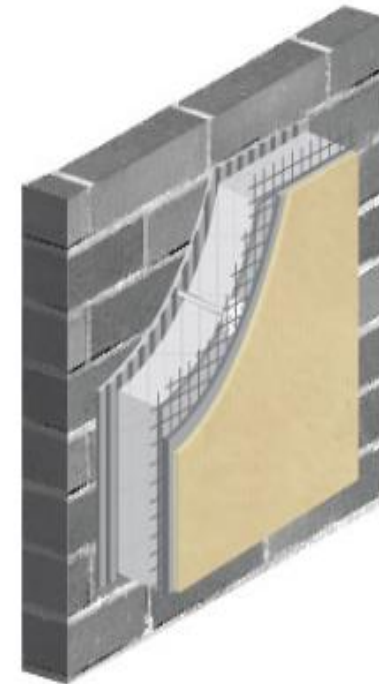
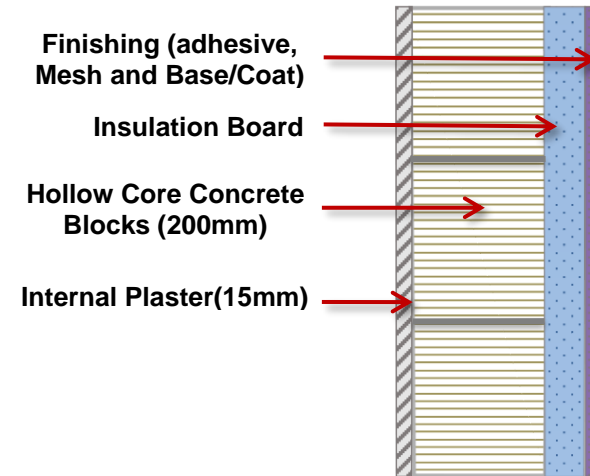

External Thermal Insulation System with Extruded Polystyrene:

- Mfg / Suppliers: Marmax (Egypt)/ Al Mezal general Trading

Sr. No.	Element	Density Kg/m ³	Thickness (mm)	Thermal Conductivity W/m.K	Thermal Resistance m ² .K/W
1	Ext. Surface Resistance				0.059
2	Internal Plaster	1800	15	0.75	0.020
3	Concrete Block	2100	200	0.885	0.226
4	XPS	35	50	0.037	1.351
5	Finishing	-	-	-	-
6	Int. Surface Resistance				0.121
Total Thermal Resistance (R) m ² .K/W					1.777
Total Thermal Transmittance (U-value) W/m².K					0.563

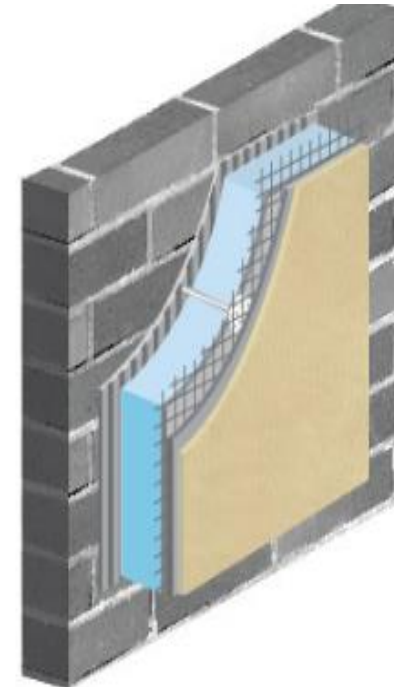
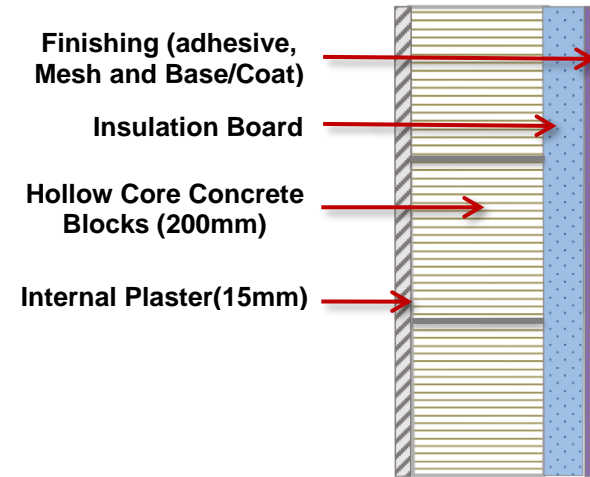

External Thermal Insulation System with Rockwool:

- Mfg / Suppliers: Terraco (UAE)/ Green Innova trading

Sr. No.	Element	Density Kg/m ³	Thickness (mm)	Thermal Conductivity W/m.K	Thermal Resistance m ² .K/W
1	Ext. Surface Resistance				0.059
2	Internal Plaster	1800	15	0.75	0.020
3	Concrete Block	2100	200	0.885	0.226
4	Rockwool	148	50	0.0376	1.330
5	Finishing	-	-	-	-
6	Int. Surface Resistance				0.121
Total Thermal Resistance (R) m ² .K/W					1.936
Total Thermal Transmittance (U-value) W/m².K					0.517

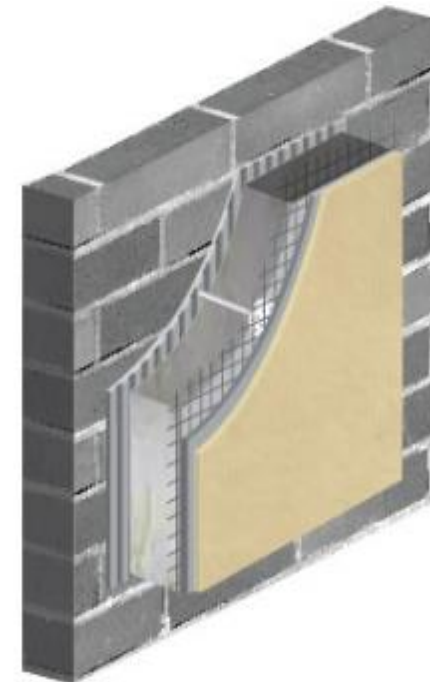
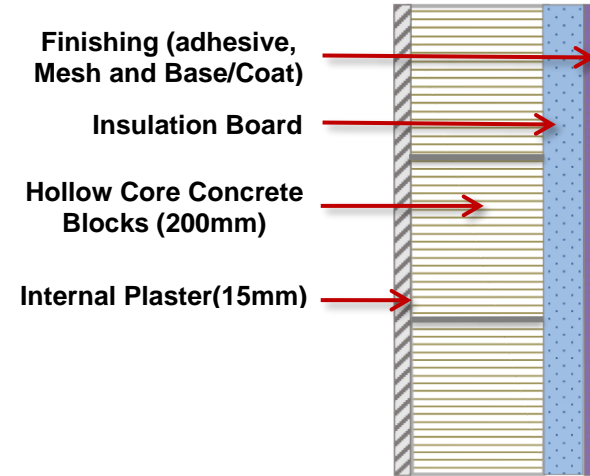

Internal Thermal Insulation System with Expanded Polystyrene

- Mfg / Suppliers: Green Products Industries(BH)/Bader Trading & Contr.

Sr. No.	Element	Density Kg/m ³	Thickness (mm)	Thermal Conductivity W/m.K	Thermal Resistance m ² .K/W
1	Ext. Surface Resistance				0.059
2	External Plaster	1800	15	0.75	0.020
3	Concrete Block	2100	200	0.885	0.226
4	EPS	20	60	0.0388	1.546
5	Gypsum Board	950	15	0.16	0.094
6	Int. Surface Resistance				0.121
Total Thermal Resistance (R) m ² .K/W					2.066
Total Thermal Transmittance (U-value) W/m².K					0.484

- Mfg / Suppliers: Iznik Trading, (BH)

Sr. No.	Element	Density Kg/m ³	Thickness (mm)	Thermal Conductivity W/m.K	Thermal Resistance m ² .K/W
1	Ext. Surface Resistance				0.059
2	External Plaster	1800	15	0.75	0.020
3	Concrete Block	2100	200	0.885	0.226
4	EPS	1300	60	0.0397	1.511
5	Gypsum Board	950	15	0.16	0.094
5	Int. Surface Resistance				0.121
Total Thermal Resistance (R) m ² .K/W					2.031
Total Thermal Transmittance (U-value) W/m².K					0.492

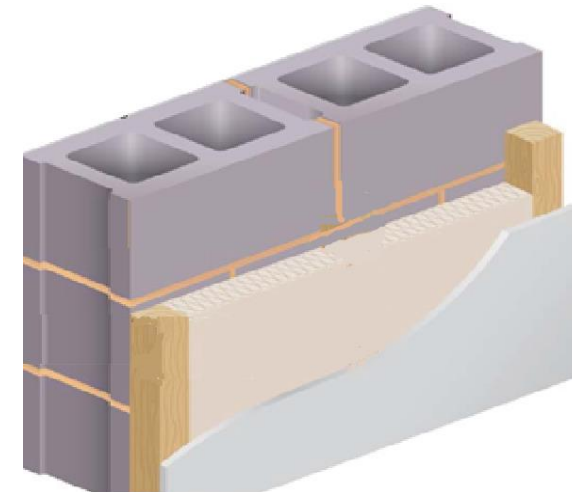
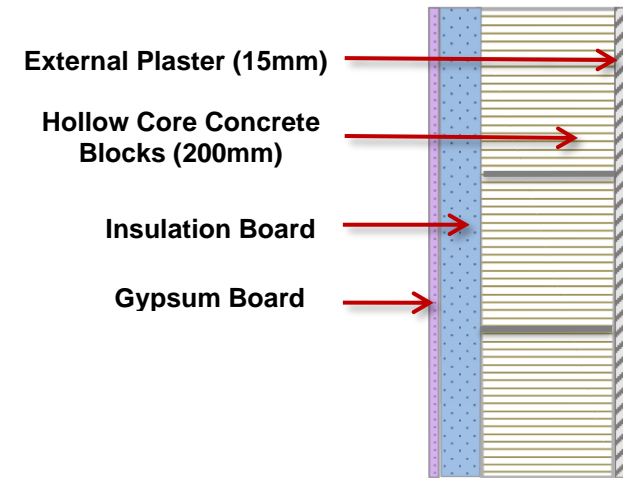

AAC Panels:

Autoclaved Aerated Concrete Panels

- Mfg / Suppliers: ESPAC Precast Aerated Company (KSA)/Dilla Decor

Sr. No.	Element	Density Kg/m ³	Thickness (mm)	Thermal Conductivity W/m.K	Thermal Resistance m ² .K/W
1	Ext. Surface Resistance				0.059
2	External Plaster	1800	15	0.75	0.020
3	AAC Panels	598	300	0.172	1.744
4	Internal Plaster	1800	15	0.75	0.020
5	Int. Surface Resistance				0.121
Total Thermal Resistance (R) m ² .K/W					1.964
Total Thermal Transmittance (U-value) W/m².K					0.509

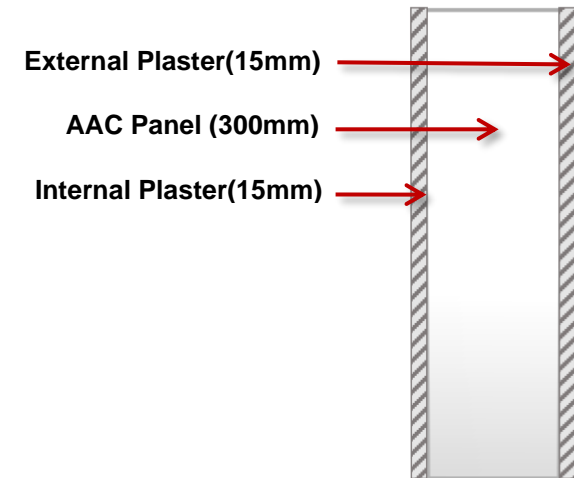

Polystyrene/ Concrete Sandwich Panel

- Mfg / Suppliers: Jehan Green Walls (UAE) / Crans Contracting

Sr. No.	Element	Density Kg/m ³	Thickness (mm)	Thermal Conductivity W/m.K	Thermal Resistance m ² .K/W
1	Ext. Surface Resistance				0.059
2	External Plaster	1800	15	0.75	0.020
3	Insulated Board	18	60	.033	1.818
4	Reinforced Concrete	2500	100	2.5	0.04
5	Insulated Board	18	60	.033	1.818
6	Internal Plaster	1800	15	0.75	0.020
7	Int. Surface Resistance				0.121
Total Thermal Resistance (R) m ² .K/W					3.896
Total Thermal Transmittance (U-value) W/m².K					0.257

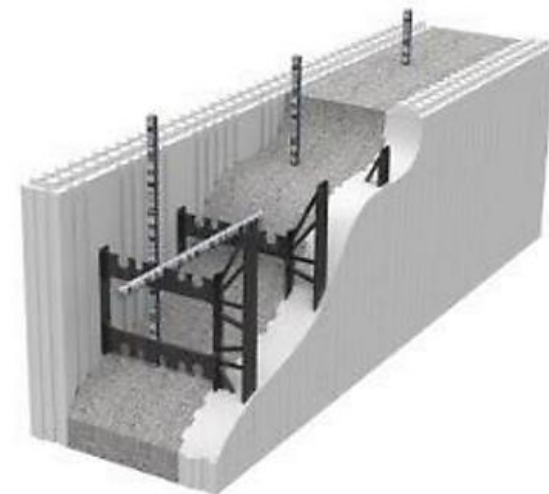
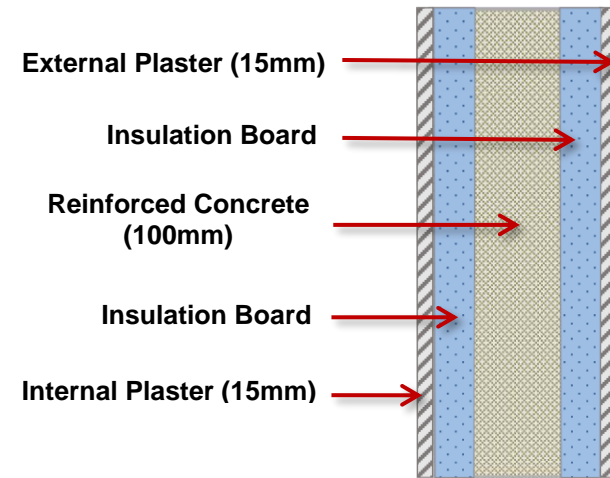

Concrete/Polystyrene Sandwich Panel

- Mfg / Suppliers: Al-Khajah Factories W.L.L..(BH) :
- JMS Eco Insulated Smart & Green Building System

Sr. No.	Element	Density Kg/m ³	Thickness (mm)	Thermal Conductivity W/m.K	Thermal Resistance m ² .K/W
1	Ext. Surface Resistance				0.059
2	External Plaster	1800	15	0.75	0.020
3	Reinforced Concrete	2500	100	2.5	0.040
4	EPS	18	70	0.041	1.707
5	Reinforced Concrete	2500	100	2.5	0.040
6	Internal Plaster	1800	15	0.75	0.020
7	Int. Surface Resistance				0.121
Total Thermal Resistance (R) m ² .K/W					1.928
Total Thermal Transmittance (U-value) W/m².K					0.519

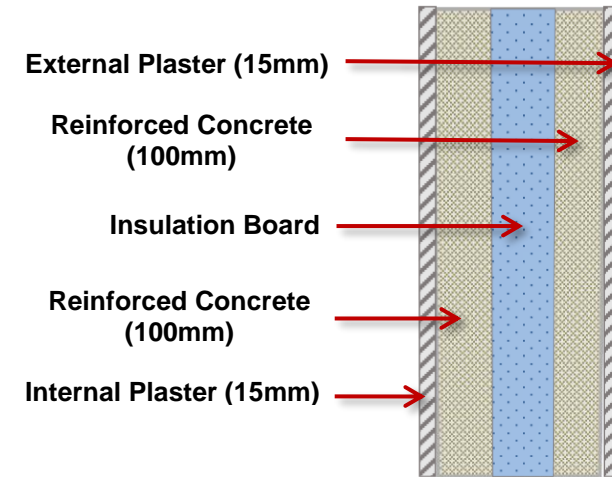

Thermal Insulation Systems for Columns & Beams/ Shear Walls

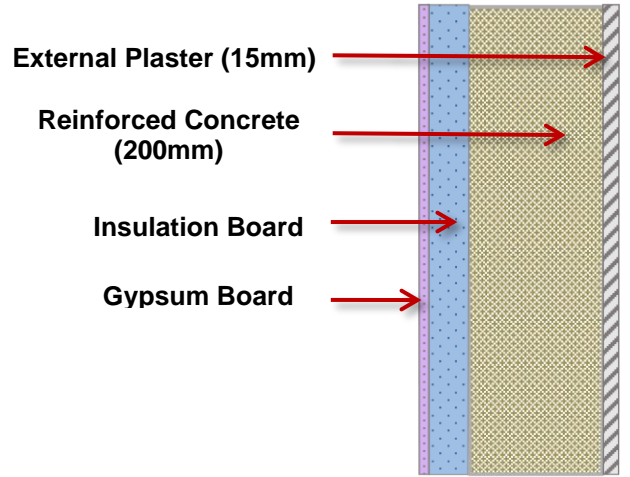
SYSTEM NAME / DESCRIPTION						CROSS SECTION / IMAGE
Internal Thermal Insulation:						
Type (1): Expanded Polystyrene:						
- Mfg / Suppliers: Noor Factory (BH)						
Sr. No.	Element	Density Kg/m ³	Thickness (mm)	Thermal Conductivity W/m.K	Thermal Resistance m ² .K/W	
1	Ext. Surface Resistance				0.059	
2	External Plaster	1800	15	0.75	0.020	
3	Reinforced Concrete	2500	200	2.5	0.08	
4	EPS	20	60	0.0397	1.511	
5	Gypsum Board	950	15	0.16	0.094	
6	Int. Surface Resistance				0.121	
Total Thermal Resistance (R) m ² .K/W					1.885	
Total Thermal Transmittance (U-value) W/m².K					0.530	

Type (2): Extruded Polystyrene:

- Mfg / Suppliers: Marmax (Egypt)/ Al Mezal general Trading

Sr. No.	Element	Density Kg/m ³	Thickness (mm)	Thermal Conductivity W/m.K	Thermal Resistance m ² .K/W
1	Ext. Surface Resistance				0.059
2	External Plaster	1800	15	0.75	0.020
3	Reinforced Concrete	2500	200	2.5	0.08
4	XPS	20	60	0.037	1.622
5	Finishing	-	-	-	-
6	Int. Surface Resistance				0.121
Total Thermal Resistance (R) m ² .K/W					1.902
Total Thermal Transmittance (U-value) W/m².K					0.526

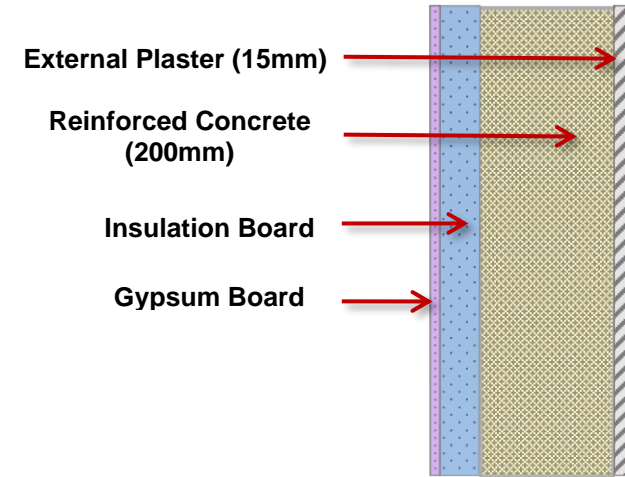

Type (3):Rockwool:

- Mfg / Suppliers: Terraco (UAE)/ Green Innova trading

Sr. No.	Element	Density Kg/m ³	Thickness (mm)	Thermal Conductivity W/m.K	Thermal Resistance m ² .K/W
1	Ext. Surface Resistance				0.059
2	External Plaster	1800	15	0.75	0.020
3	Reinforced Concrete	2500	200	2.5	0.08
4	Rockwool	20	60	0.0376	1.596
5	Finishing	-	-	-	-
6	Int. Surface Resistance				0.121
Total Thermal Resistance (R) m ² .K/W					1.876
Total Thermal Transmittance (U-value) W/m².K					0.533

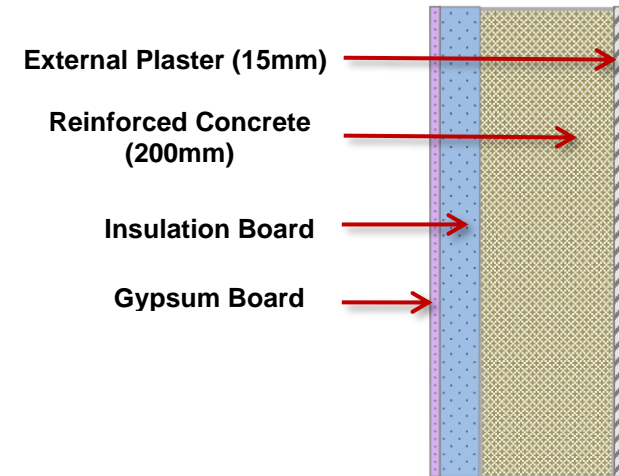

External Thermal Insulation:

Type (1): Expanded Polystyrene:

- Mfg / Suppliers: : Noor Factory (BH)

Sr. No.	Element	Density Kg/m ³	Thickness (mm)	Thermal Conductivity W/m.K	Thermal Resistance m ² .K/W
1	Ext. Surface Resistance				0.059
2	Finishing	-	-	-	-
3	EPS	20	60	0.0397	1.511
4	Reinforced Concrete Block	2100	200	0.885	0.226
5	Internal Plaster	1800	15	0.75	0.020
6	Int. Surface Resistance				0.121
Total Thermal Resistance (R) m ² .K/W					1.937
Total Thermal Transmittance (U-value) W/m².K					0.516

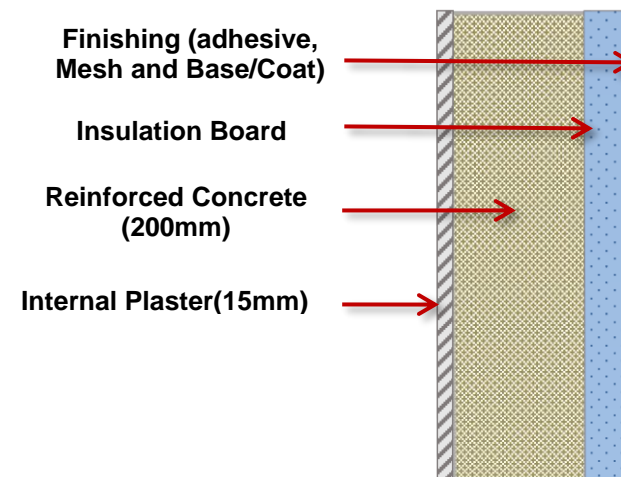

Type (2): Extruded Polystyrene:

- Mfg / Suppliers: Marmax (Egypt)/ Al Mezal general Trading

Sr. No.	Element	Density Kg/m ³	Thickness (mm)	Thermal Conductivity W/m.K	Thermal Resistance m ² .K/W
1	Ext. Surface Resistance				0.059
2	Finishing	-	-	-	-
3	XPS	35	50	0.037	1.351
4	Reinforced Concrete	2100	200	0.885	0.226
5	Internal Plaster	1800	15	0.75	0.020
6	Int. Surface Resistance				0.121
Total Thermal Resistance @ m ² .K/W					1.777
Total Thermal Transmittance (U-value) W/m².K					0.563

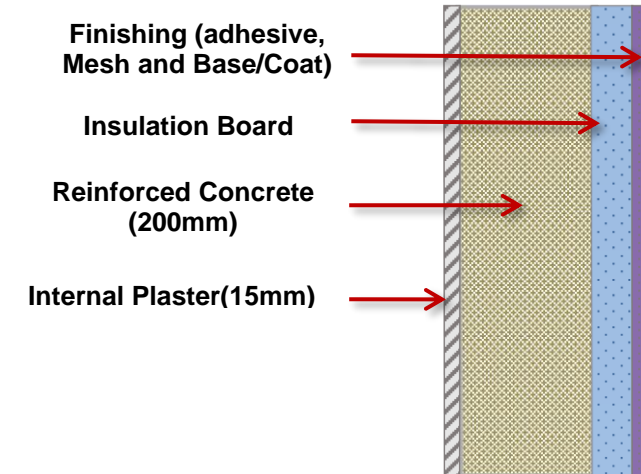

Type (3):Rockwool:

- Mfg / Suppliers: Terraco (UAE)/ Green Innova trading

Sr. No.	Element	Density Kg/m ³	Thickness (mm)	Thermal Conductivity W/m.K	Thermal Resistance m ² .K/W
1	Ext. Surface Resistance				0.059
2	Finishing	-	-	-	-
3	Rockwool	148	50	0.037	1.330
4	Reinforced Concrete	2100	200	0.885	0.226
5	Internal Plaster	1800	15	0.75	0.020
6	Int. Surface Resistance				0.121
Total Thermal Resistance ® m ² .K/W					1.936
Total Thermal Transmittance (U-value) W/m².K					0.517

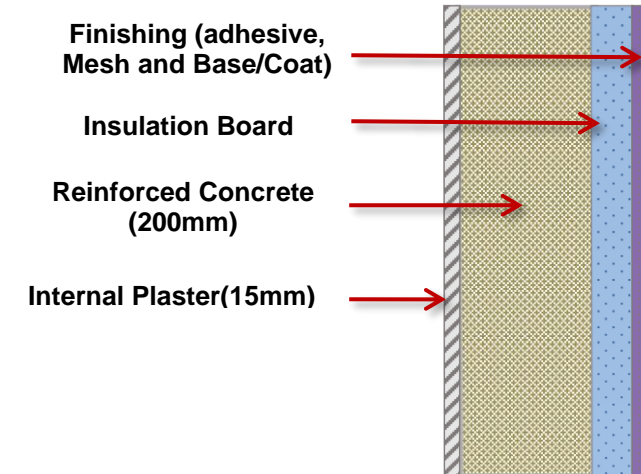

Appendix (2)

Thermal Insulation Implementation Forms



Thermal Insulation Implementation Inspection Form

This form should be filled for each floor/roof/glass when intending to start the installation of thermal insulation and send it at least ten days before its completion.

Building Permit No.: _____	Application no.: _____		
Engineering office: _____	Owner name: _____		
Building type: _____	Build-up area: _____	No. of Floors: _____	
Building No.: _____	Road No.: _____	Block No.: _____	Area: _____

Thermal Insulation installed as per implementation forms:	<input type="checkbox"/> Yes	<input type="checkbox"/> No
--	------------------------------	-----------------------------

No.	Description	E.O. Remarks (Type, Material, Thickness, ..etc)	EWA Remarks
1	Wall Insulation		
2	Wall of light well/shaft/void		
3	Columns / Beams Insulation		
4	Concrete / Shear Wall		
5	Roof Insulation		
6	Roof Coating		
7	Floor/Ceiling Insulation		
8	Glass		
9	Spandrel area of curtain wall		

Remarks:

Attached Documents:
<input type="checkbox"/> Building permit <input type="checkbox"/> Address card for entrance <input type="checkbox"/> Drawings for the inspected area <input type="checkbox"/> Approved Implementation forms for the inspected area <input type="checkbox"/> Pictures for the inspected area

Engineering Office/Authorized Engineer	Electricity & Water Conservation Engineer:
Name: _____	Name: _____
Sign: _____ Phone: _____	Sign: _____
Date: _____ ((Stamp))	Date: _____



Roof Coating Form

Building Permit No.: _____	Application no.: _____		
Engineering office: _____	Owner name: _____		
Building type: _____	Build-up area: _____	No. of Floors: _____	
Building No.: _____	Road No.: _____	Block No.: _____	Area: _____

Roof Coating:
Product Name (approved by Ewa): _____
<i>Note: Roofs containing photovoltaic panels may be exempted from roof coating.</i>

Remarks:

We Engineering Office/Authorized Engineer undersigned hereby declare that all information provided in this form is complete with all details and attach supporting document as required, and found it complied with EWA's Thermal Insulation Regulation	
Engineering Office/Authorized Engineer:	Ewa's Approval:
Name: _____	Reviewed by: _____
Sign: _____	Sign: _____
Date: _____ ((Stamp))	Date: _____



Thermal Insulation Implementation
Glass Approval Form

Building Permit No.:	_____	Application no.:	_____				
Engineering office:	_____	Owner name:	_____				
Building type:	_____	Build-up area:	_____	No. of Floors:	_____		
Building No.:	_____	Road No.:	_____	Block No.:	_____	Area:	_____

Glass Details:

No	Description	Details	Remarks
1	Application	<input type="checkbox"/> Windows/Doors <input type="checkbox"/> Curtain Wall <input type="checkbox"/> Showrooms/Shopfront <input type="checkbox"/> Skylight	
2	Manufacturer & Brand		
3	Local Agent - Supplier / contact details		
4	Aluminum Fabricator / contact details/ Frame Type		
5	Product Description		

Required Documents:

No	Description	Attachment	Remarks
1	Glass Manufacturer certificate (signed and stamped)	<input type="checkbox"/> Yes <input type="checkbox"/> No <input type="checkbox"/> N/A	
2	Aluminum Fabricator certificate (signed and stamped)	<input type="checkbox"/> Yes <input type="checkbox"/> No <input type="checkbox"/> N/A	
3	Glass Data Sheet	<input type="checkbox"/> Yes <input type="checkbox"/> No <input type="checkbox"/> N/A	
4	Glass area calculation schedule/Shop drawings	<input type="checkbox"/> Yes <input type="checkbox"/> No <input type="checkbox"/> N/A	
5	Glass sample photo with project and manufacturer details sticker stamped by E.O.	<input type="checkbox"/> Yes <input type="checkbox"/> No <input type="checkbox"/> N/A	

Remarks:

We Engineering Office/Authorized Engineer undersigned hereby declare that the glass approval form is complete with all details and attach supporting documents and drawings as required, and found it complied with EWA's Thermal Insulation Regulation

Engineering Office/Authorized Engineer: Name: _____ Sign: _____ Phone: _____ Date: _____ ((Stamp))	EWA's Approval: Reviewed by: _____ Sign: _____ Date: _____
--	--



Thermal Insulation Implementation Modification Form

E.O. should submit TII Modification Form & obtain approval before incorporating any changes on the site

Building Permit No.: _____	Application no.: _____		
Engineering office: _____	Owner name: _____		
Building type: _____	Build-up area: _____	No. of Floors: _____	
Building No.: _____	Road No.: _____	Block No.: _____	Area: _____

Tick the appropriate box for the proposed change/s:

No	Change of	Required Documents	Remarks
1	<input type="checkbox"/> Owner	<input type="checkbox"/> Supporting document for transfer of ownership <input type="checkbox"/> Tel No.& e-mail for the new owner <input type="checkbox"/> Copy of CPR/CR	
2	<input type="checkbox"/> Engineering Office	<input type="checkbox"/> Form of changing Engineering Office <input type="checkbox"/> No objection letter from previous E.O.	
3	<input type="checkbox"/> Roof insulation/coating materials	<input type="checkbox"/> Approval of the new materials <input type="checkbox"/> New materials TII forms <input type="checkbox"/> Roof cross section <input type="checkbox"/> Benayat TII data	
4	<input type="checkbox"/> Wall insulation materials	<input type="checkbox"/> Approval of the new materials <input type="checkbox"/> New materials TII forms <input type="checkbox"/> Wall cross section <input type="checkbox"/> Benayat TII data	
5	<input type="checkbox"/> Glass type	<input type="checkbox"/> Manufacturer's performance data sheet <input type="checkbox"/> Glass selection details <input type="checkbox"/> Benayat TII data	
6	<input type="checkbox"/> Glass area	<input type="checkbox"/> Glass selection details <input type="checkbox"/> Architecture / Elevations drawings <input type="checkbox"/> Schedule of doors & windows <input type="checkbox"/> Calculation sheets for glass/external surface	

Remarks:

We Engineering Office/Authorized Engineer undersigned hereby declare that the modification form is complete with all details and attach supporting documents and drawings as required, and found it complied with EWA's Thermal Insulation Regulation

Engineering Office/Authorized Engineer:

Name: _____

Sign: _____

Date: _____

((Stamp))

EWA's Approval:

Reviewed by: _____

Sign: _____

Date: _____



Thermal Insulation Implementation Completion Checklist

Building Permit No.: _____	Application no.: _____		
Engineering office: _____	Owner name: _____		
Building type: _____	Build-up area: _____	No. of Floors: _____	
Building No.: _____	Road No.: _____	Block No.: _____	Area: _____

Requirements & Documents:

No.	Description	Yes	No	N/A	Remarks
1	TI Materials Delivery Notes				
2	Municipality forms				
3	Inspection Completed as per EWA Requirements				
4	TI Completion Certificate				
5	Copy of Building Permit (BP)				
6	Copy of Address Card				
7	EDD Approved load				
8	TI Modification (If any)				
9	Building Photo for Progress/Completion				

We Engineering Office/Authorized Engineer undersigned hereby declare that audit completion form is complete with all details and attach documents as required, and found it complied with EWA's Thermal Insulation Regulation	
Engineering Office/Authorized Engineer: Name: _____ Sign: _____ Phone: _____ Date: _____ <p style="text-align: right;">((Stamp))</p>	EWA's Approval: Reviewed by: _____ Sign: _____ Date: _____



Thermal Insulation Implementation Audit Checklist

Engineering Office Name: _____
Category: _____ CR No.: _____
CRPEP No.: _____
Discipline(s): _____ Telephone no. : _____

Requirements & Documents:

No.	Description	Yes	No	N/A	Remarks
1	Valid E.O. CRPEP.				
2	Valid E.O. Registration Certificate (CR).				
3	List of Project for Benayat System.				
4	List of Project for Online Building Permit System.				
5	Name of TII Authorized Engineers.				1. 2.
6	Pending from pervious Audit				

We Engineering Office/Authorized Engineer undersigned hereby declare that audit checklist form is complete with all details and attach documents as required, and found it complied with EWA's Thermal Insulation Regulation	
Engineering Office/Authorized Engineer: Name: _____ Sign: _____ Phone: _____ Date: _____ ((Stamp))	EWA's Approval: Reviewed by: _____ Sign: _____ Date: _____

التاريخ:

تعهد بتطبيق العزل الحراري على المبنى

اتعهد انا المالك للمبنى / العقار رقم: -----، الواقع تحت

عنوان: -----

بتطبيق العزل الحراري في المبنى المذكور أعلاه، وذلك لجميع الجدران والأعمدة والجسور والأسقف والزجاج، وكذلك طلاء الاسطح لتصبح عاكسة لأشعة الشمس حسب المواصفات المعتمدة والمصادق عليها من قبل وحدة العزل الحراري في هيئة الكهرباء و الماء.

كما وسأقوم بالتنسيق مع المكتب الاستشاري: ----- المشرف على المبنى، وذلك لمتابعة مراحل العزل الحراري.

وأتعهد بالتنسيق مع المكتب الاستشاري للكشف والمعاينة والموافقة على العزل الحراري للمبنى قبل المسح والصبغة وتركيب الزجاج العازل، وأقر بتحمل جميع التبعات والإجراءات المتخذة هيئة الكهرباء و الماء في حال المخالفة واتحمل كافة المسئوليات القانونية والمادية، بما في ذلك عدم توصيل خدمة الكهرباء للمبنى.

اسم المتعهد (مالك المشروع):

الرقم الشخصي:

التوقيع:

توقيع وختم المكتب الهندسي:

Appendix (3)

Approval Procedures for Thermal Insulation Products



Procedure of Registration for Thermal Insulation Products and Cool Roof:

For using any thermal insulation product of buildings in Bahrain, Manufacturers or their agents/dealers (if the manufacturer has no CR -Commercial Registration- in Bahrain) should submit Thermal Insulation Product Approval Form (Attached) with the following documents:

- A Valid CR (Commercial Registration Certificate) for the applicant.
- An Authorization from the manufacturer, if the applicant is not the manufacturer, confirming that the applicant is authorized to get the required approvals from the concerned authorities.
- An Approval Certificate for the thermal insulation product from Directorate of Civil Defense, except for cool roof paint, where it is not required.
- A Declaration of conformity letter has to be provided by the manufacturer for test reports dated more than 2 years from the requested date, as long as it does not exceed 5 years ago. However, if the test report dated with more than 5 years ago, a new test report has to be provided.
- Product specifications/ catalogues.
- Test report from an independent testing laboratory for the thermal insulation material/ cool roof paint of the product. Accreditation (as per ISO-17025) along with accreditation scope are required from the laboratory in the scope of the test report. The tolerance error (Uncertainty measurement) of the test shall be mentioned in the test report. The test shall be conducted based on one of the following standards:

Thermal Insulation Products	Cool Roof Paints
<p>The test shall be conducted under the mean temperature of 35°C & 60% of RH based on the following standards:</p> <ul style="list-style-type: none">Method-1: Guarded Hot Plate (ISO 8302 / ASTM C177/ BS EN 12664/ BS EN 12667/ BS EN 12939).Method 2: Heat Flow Meter (ISO 8301/ ASTM C518/ BS EN 12664/ BS EN 12667/ BS EN 12939).Method 3: Guarded Hot Box Method (ISO 8990 / ASTM C1363).	<ul style="list-style-type: none">Solar Reflectance Tests shall be conducted based upon one of the following test methods:<ul style="list-style-type: none">ANSI/CRRC S100.ASTM E903 in conjunction with E891 analyzed using factors appropriate for an air mass value of 1.5.ASTM E1918.ASTM C1549, using an air mass value of 1.5CRRC-1 Test Method #1, using an air mass value of 1.5:<ul style="list-style-type: none">Tile Test MethodTile Template MethodWood MethodThermal Emittance Test shall be conducted in accordance with ASTM C1371 or ANSI/CRRC S100.

- The Registration certificate will be valid for two years period from the issue date; unless the test report validity exceeds 5 years before it completes two years from registration issue date, where in this case, the validity date of the registration certificate will be the same as the test report validity date and cannot be extended for another two years after the test report date exceeded its validity.
- Electricity Conservation Section in Electricity Distribution Directorate (EDD), shall study the submittals & evaluate the suitability of the product for thermal insulation in Bahrain, and issue a certificate of approval to the application if satisfactory.
- Electricity Conservation Section reserves the right in the future to request additional documents or withdraw its approval if violation found.

The above documents should be sent to EWA by e-mail (ECS@ewa.bh). The local vendor should apply for registration.



Thermal Insulation Product Application Form

Under Ministerial Order No: 149 of the year (2018) for Thermal Insulation in Buildings

Type of Request	<input type="checkbox"/> New Registration	<input type="checkbox"/> Renewal	
Application for:	<input type="checkbox"/> Wall	<input type="checkbox"/> Roof	<input type="checkbox"/> Cool Roof
Product Name:		
Product Details:	Product Description:		
	Wall & Roof		Cool Roof
	Measured thermal conductivity	Measured Emittance	Measured Solar Reflectance
	Price (BD/Unit) _____, where <u>unit</u> : is the standard <u>measurement</u> for area.		

1. Applicant and Manufacturer Details:

Applicant Details:	Name of Establishment:		
	Address:		
	Contact Person:		
	Designation:	Mobile No.:	
	Tel:	E-mail:	
Manufacturer Details:	Name of Manufacturer:		
	Address:		
	Contact Person:		
	Designation:	Mobile No.:	
	Tel:	E-mail:	

2. Attachments Details:

Attachments:	<input type="checkbox"/> Valid Commercial Registration Certificate (CR)	<input type="checkbox"/> Mfg. authorization letter
	<input type="checkbox"/> Brochures or other relevant documents	<input type="checkbox"/> Civil Defense Certificate
	<input type="checkbox"/> Thermal Test Report	<input type="checkbox"/> Declaration of Conformity letter
		<input type="checkbox"/> Product Sample

3. Applicant's Undertaking and Commitments:

The applicant undersigned hereby declare that all information and attachments provided along with this request are true and complied with requirements in the Thermal Insulation Regulation order.

Authorized Stamp	Name:
	Designation:
	Date:
	Signature:

4. EWA Approval: (For EWA Official Use Only):